

INECO[®] Autorizovaný distribútor



PART OF THE ATLAS COPCO GROUP



INECO[®]

**Air and Vacuum
Components**

www.in-eco.sk

PRETLAK

**KATALÓG ŠTANDARDNÝCH AGREGÁTOV
S ROOTOVÝM DÚCHADLOM RADY BAH**

BAH TOP 5

1

Unikátna konštrukcia

2

Výhodný pomer cena - výkon

3

Extrémne malé zástavbové rozmery

4

Jednoduchá údržba a servis

5

Jednoduchá manipulácia

Hlavné aplikácie:

Prevzdušňovacie
systémy

Čistiarne
odpadových vôd

Pneudoprava

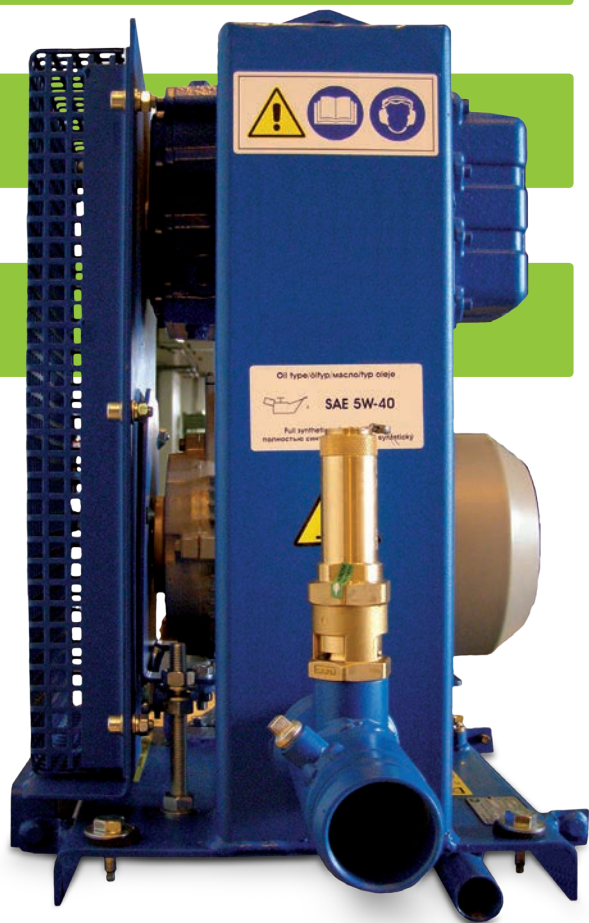



ROOTS DÚCHADLÁ



Dúchadlové sústrojenstvá sú určené pre bezolejovú dopravu a stláčanie vzduchu.

Prevedenie: Sústrojenstvá sú kompletované so základným príslušenstvom potrebným na bezporuchovú prevádzku. Dúchadlo je poháňané elektromotorom pomocou prevodu klinovými remeňmi.

Základné vybavenie

1. Dúchadlo s trojzubými rotormi
2. Elektromotor
3. Nosný rám s tlmičom stlačeného vzduchu
4. Tlmič sania s hrubou filtráciou
5. Remeňový prevod
6. Kryt remeňového prevodu, pokiaľ nie sú sústrojenstvá namontované s protihlukovým krytom
7. Poistný ventil Herose
8. Spätná klapka na výtlaku
9. Tlaková hadica na výstupe
10. 1 x Kompletná technická dokumentácia

Osobitné príslušenstvo

1. Kompenzátor s prírubou na výstupe
2. Protihlukový kryt
3. Manometer na výtlaku
4. Filter Solberg pre jemnú filtráciu
5. Elektrická riadiaca jednotka v samostatnej skrini
6. Frekvenčné meniče

Inžinierske služby

1. Softvér na určenie optimálneho typu výkonnosti dúchadla, príkonu, teploty vzdušniny na výtlaku z dúchadla, optimalizácia elektromotorov, ...
2. Poradenská činnosť v oblasti rozvodov stlačeného vzduchu
3. Výpočty nútenej ventilácie strojovne

Klimatické podmienky

Klimatické prevedenie výrobku: WT ČSN EN 60721-3-3
 Kategória umiestnenia výrobku: ČSN EN 60721-3-3
 3K7L, 3B1, 3C3, 3S2, 3M3

Tlakové pomery štandardného sústrojenstva

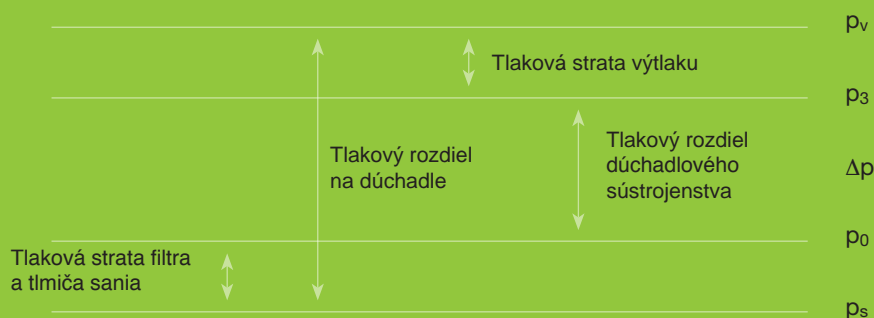

p_s – tlak na sacej prírubu dúchadla, je nižší ako tlak atmosférický o tlakovú stratu vo filtračnej vložke a v tlmiči sania

p_0 – tlak atmosférický

p_3 – tlak na výtláčnej prírubu z dúchadlového sústrojenstva, je nižší ako tlak na výtláčnej prírubu dúchadla o tlakovú stratu v tlmiči tlaku a tlakovú stratu na spätnej klapke, T-kusu poistného ventilu a kompenzátora

p_v – tlak na výtláčnej prírubu dúchadla

Katalóg je aktualizovaný 1 x ročne. Vzhľadom na vývoj a zlepšovanie úžitkových vlastností výrobkov LUTOS môže v priebehu tejto doby dôjsť k drobným zmenám údajov uvedených v katalógu. Odporúčame preto konkrétne údaje overiť v aktualizovanom katalógu vo formáte PDF na stránkach www.lutos.cz.

BAH 6/10

DÚCHADLOVÉ SÚSTROJENSTVÁ PRE PRETLAK

Δp [kPa]	BAH 6/10											
10	Q [m ³ ·h ⁻¹]					58	65	77	87	95	107	
	T ₃ [°C]					29	29	29	29	29	29	
	P _e [kW]					0,2	0,23	0,27	0,3	0,32	0,36	
	P _m [kW]					0,37	0,37	0,37	0,37	0,55	0,55	
	n [min ⁻¹]					2740	3050	3523	3947	4250	4755	
	n _m [min ⁻¹]					2740	2740	2740	2740	2800	2800	
	Elmotor					71-2	71-2	71-2	71-2	71-2	71-2	
	i					125/125	118/106	180/140	170/118	170/112	180/106	
	X					1/XPZ	1/XPZ	1/XPZ	1/XPZ	1/XPZ	1/XPZ	
	L _{mA} [dB]					70/78	70/79	71/81	72/83	72/84	73/85	
20	Q [m ³ ·h ⁻¹]	23	28	38	49	60	65	77	83	93	106	
	T ₃ [°C]	45	44	42	40	40	39	39	39	38	38	
	P _e [kW]	0,2	0,24	0,3	0,37	0,43	0,47	0,54	0,57	0,63	0,71	
	P _m [kW]	0,37	0,37	0,37	0,55	0,55	0,75	0,75	0,75	1,1	1,1	
	n [min ⁻¹]	1448	1644	2046	2503	2958	3178	3671	3893	4294	4837	
	n _m [min ⁻¹]	1370	1370	2740	2800	2800	2855	2855	2855	2845	2845	
	Elmotor	71-4	71-4	71-2	71-2	71-2	80-2	80-2	80-2	80-2	80-2	
	i	112/106	180/150	112/150	118/132	112/106	118/106	180/140	180/132	160/106	170/100	
	X	1/XPZ	1/XPZ	1/XPZ	1/XPZ	1/XPZ	1/XPZ	1/XPZ	1/XPZ	1/XPZ	1/XPZ	
	L _{mA} [dB]	67/78	68/78	68/79	69/79	70/79	70/80	72/82	72/84	73/85	74/86	
30	Q [m ³ ·h ⁻¹]	21	26	35	45	55	63	75	80	91	104	
	T ₃ [°C]	61	59	55	52	51	50	49	49	48	48	
	P _e [kW]	0,3	0,36	0,44	0,53	0,62	0,69	0,8	0,85	0,94	1,06	
	P _m [kW]	0,55	0,55	0,55	0,75	0,75	1,1	1,1	1,1	1,5	1,5	
	n [min ⁻¹]	1473	1674	2045	2422	2855	3167	3658	3880	4317	4856	
	n _m [min ⁻¹]	1395	1395	2800	2855	2855	2845	2845	2845	2860	2860	
	Elmotor	80-4	80-4	71-2	80-2	80-2	80-2	80-2	80-2	90-2	90-2	
	i	112/106	180/150	112/150	112/132	112/112	118/106	180/140	180/132	160/106	180/106	
	X	1/XPZ	1/XPZ	1/XPZ	1/XPZ	1/XPZ	1/XPZ	1/XPZ	1/XPZ	1/XPZ	1/XPZ	
	L _{mA} [dB]	68/79	70/80	70/80	71/80	71/81	71/82	73/82	73/85	74/86	75/87	
40	Q [m ³ ·h ⁻¹]	20	25	33	43	53	62	74	79	90	103	
	T ₃ [°C]	80	75	69	65	62	62	60	60	59	58	
	P _e [kW]	0,4	0,48	0,6	0,7	0,82	0,92	1,06	1,1	1,26	1,41	
	P _m [kW]	0,55	0,75	0,75	1,1	1,1	1,5	1,5	1,5	2,2	2,2	
	n [min ⁻¹]	1473	1674	2132	2414	2845	3203	3683	3878	4393	4890	
	n _m [min ⁻¹]	1395	1395	2855	2845	2845	2860	2860	2860	2880	2880	
	Elmotor	80-4	80-4	80-2	80-2	80-2	90-2	90-2	90-2	90-2	90-2	
	i	112/106	180/150	112/150	112/132	112/112	112/100	170/132	160/118	180/118	180/106	
	X	1/XPZ	1/XPZ	1/XPZ	1/XPZ	1/XPZ	1/XPZ	1/XPZ	1/XPZ	1/XPZ	1/XPZ	
	L _{mA} [dB]	69/78	70/80	70/80	71/80	72/81	72/82	73/83	74/85	74/87	75/88	
50	Q [m ³ ·h ⁻¹]	19	24	34	42	52	61	73	78	89	102	
	T ₃ [°C]	99	92	81	78	74	72	71	70	69	68	
	P _e [kW]	0,5	0,6	0,76	0,87	1,03	1,14	1,3	1,4	1,56	1,76	
	P _m [kW]	0,75	0,75	1,1	1,1	1,5	1,5	2,2	2,2	2,2	2,2	
	n [min ⁻¹]	1473	1674	2124	2414	2860	3203	3709	3905	4393	4890	
	n _m [min ⁻¹]	1395	1395	2845	2845	2860	2860	2880	2880	2880	2880	
	Elmotor	80-4	80-4	80-2	80-2	90-2	90-2	90-2	90-2	90-2	90-2	
	i	112/106	180/150	112/150	112/132	112/112	112/100	170/132	160/118	180/118	180/106	
	X	1/XPZ	1/XPZ	1/XPZ	1/XPZ	1/XPZ	1/XPZ	1/XPZ	1/XPZ	1/XPZ	1/XPZ	
	L _{mA} [dB]	70/78	70/80	71/80	71/81	72/82	73/83	74/83	75/85	76/87	76/89	
60	Q [m ³ ·h ⁻¹]	18	23	34	41	52	60	72	77	86	98	
	T ₃ [°C]	117	108	95	91	86	85	82	81	81	79	
	P _e [kW]	0,6	0,73	0,92	1,05	1,23	1,38	1,59	1,68	1,9	2,1	
	P _m [kW]	1,1	1,1	1,5	1,5	1,5	2,2	2,2	2,2	3,8	3,8	
	n [min ⁻¹]	1495	1698	2135	2427	2860	3226	3709	3905	4280	4772	
	n _m [min ⁻¹]	1415	1415	2860	2860	2860	2880	2880	2880	2810	2810	
	Elmotor	90-4	90-4	90-2	90-2	90-2	90-2	90-2	90-2	90-2	90-2	
	i	112/106	180/150	112/150	112/132	112/112	112/100	170/132	160/118	180/118	180/106	
	X	1/XPZ	1/XPZ	1/XPZ	1/XPZ	1/XPZ	1/XPZ	1/XPZ	1/XPZ	1/XPZ	1/XPZ	
	L _{mA} [dB]	70/79	71/80	71/80	72/82	73/82	74/83	75/84	75/86	77/88	77/90	
70	Q [m ³ ·h ⁻¹]		23	31	40	51	60	66	74	86	97	
	T ₃ [°C]		125	112	104	98	96	94	93	91	90	
	P _e [kW]		0,85	1,01	1,22	1,45	1,6	1,8	1,9	2,2	2,4	
	P _m [kW]		1,1	1,5	1,5	2,2	2,2	2,2	3,8	3,8	3,8	
	n [min ⁻¹]		1698	2021	2427	2880	3226	3497	3810	4286	4772	
	n _m [min ⁻¹]		1415	2860	2860	2880	2880	2880	2810	2810	2810	
	Elmotor		90-4	90-2	90-2	90-2	90-2	90-2	90-2	90-2	90-2	
	i		180/150	106/150	112/132	112/112	112/100	170/140	160/118	180/118	180/106	
	X		1/XPZ	1/XPZ	1/XPZ	1/XPZ	1/XPZ	1/XPZ	1/XPZ	1/XPZ	1/XPZ	
	L _{mA} [dB]		71/80	71/81	72/82	73/83	74/83	75/84	76/87	78/89	78/92	

Δp [kPa]	BAH 10/30											
30	Q [m ³ ·h ⁻¹]	83	99	122	133	153	180	201	236	253	268	304
	T ₃ [°C]	55	53	52	51	50	50	50	50	49	49	48
	P _e [kW]	1,1	1,2	1,4	1,5	1,7	1,95	2,2	2,6	2,6	2,8	3,2
	P _m [kW]	1,5	1,5	2,2	2,2	2,2	3	3	4	4	4	4
	n [min ⁻¹]	2021	2296	2688	2880	3214	3673	4046	4648	4923	5187	5810
	n _m [min ⁻¹]	2860	2860	2880	2880	2880	2890	2890	2905	2905	2905	2905
	Elmotor	90-2	90-2	90-2	90-2	90-2	100-2	100-2	112-2	112-2	112-2	112-2
	i	106/150	106/132	140/150	125/125	125/112	150/118	140/100	200/125	200/118	200/112	200/100
	X	1/XPZ	1/XPZ	1/XPZ	1/XPZ	1/XPZ	1/XPZ	1/XPA	1/XPA	1/XPA	1/XPA	1/XPA
	L _{mA} [dB]	70/80	70/81	71/81	72/82	73/83	73/84	73/85	75/87	76/89	77/90	80/94
	40	Q [m ³ ·h ⁻¹]	79	95	118	129	149	172	198	233	250	266
T ₃ [°C]		70	67	64	64	62	62	61	61	59	59	58
P _e [kW]		1,4	1,6	1,9	2	2,25	2,6	2,92	3,4	3,5	3,7	4,2
P _m [kW]		2,2	2,2	3	3	3	4	4	5,5	5,5	5,5	5,5
n [min ⁻¹]		2035	2312	2697	2890	3225	3631	4067	4680	4957	5223	5850
n _m [min ⁻¹]		2880	2880	2890	2890	2890	2905	2905	2925	2925	2925	2925
Elmotor		90-2	90-2	100-2	100-2	100-2	112-2	112-2	132-2	132-2	132-2	132-2
i		106/150	106/132	140/150	125/125	125/112	140/112	140/100	200/125	200/118	200/112	200/100
X		1/XPZ	1/XPZ	1/XPZ	1/XPA	1/XPA	1/XPA	1/XPA	1/XPA	1/XPA	1/XPA	1/XPA
L _{mA} [dB]		71/80	71/81	71/82	72/83	73/84	73/85	74/86	76/87	77/89	78/90	81/94
50		Q [m ³ ·h ⁻¹]	74	91	114	126	146	169	201	230	247	262
	T ₃ [°C]	85	74	77	75	73	73	72	71	69	69	68
	P _e [kW]	1,8	2	2	2,52	2,81	3,2	3,7	4,2	4,4	4,6	5,5
	P _m [kW]	2,2	3	3	4	4	4	5,5	5,5	5,5	5,5	7,5
	n [min ⁻¹]	2035	2312	2697	2905	3242	3631	4179	4680	4957	5223	5860
	n _m [min ⁻¹]	2880	2890	2890	2905	2905	2905	2925	2925	2925	2925	2930
	Elmotor	90-2	100-2	100-2	112-2	112-2	112-2	132-2	132-2	132-2	132-2	132-2
	i	106/150	112/140	140/150	125/125	125/112	140/112	200/140	200/125	200/118	200/112	200/100
	X	1/XPA	1/XPA	1/XPA	1/XPA	1/XPA	1/XPA	1/XPA	1/XPA	1/XPA	1/XPA	1/XPA
	L _{mA} [dB]	71/81	71/82	71/83	73/83	73/85	74/85	75/86	77/88	77/90	79/91	82/95
	60	Q [m ³ ·h ⁻¹]	70	88	105	123	144	179	198	227	244	260
T ₃ [°C]		103	96	93	88	85	84	83	82	79	79	78
P _e [kW]		2,1	2,4	3	3	3,4	4,1	4,4	5	5,2	5,5	6,2
P _m [kW]		3	3	4	4	5,5	5,5	5,5	7,5	7,5	7,5	7,5
n [min ⁻¹]		2023	2312	2596	2905	3264	3861	4179	4688	4966	5232	5860
n _m [min ⁻¹]		2890	2890	2905	2905	2925	2925	2925	2930	2930	2930	2930
Elmotor		100-2	100-2	112-2	112-2	132-2	132-2	132-2	132-2	132-2	132-2	132-2
i		112/160	112/140	118/132	125/125	125/112	132/100	200/140	200/125	200/118	200/112	200/100
X		1/XPA	1/XPA	1/XPA	1/XPA	1/XPA	1/XPA	1/XPA	1/XPA	1/XPA	1/XPA	1/XPA
L _{mA} [dB]		72/81	72/82	72/83	73/84	74/85	74/86	75/87	77/89	78/90	79/92	82/96
70		Q [m ³ ·h ⁻¹]	67	85	102	121	141	176	195	225	241	257
	T ₃ [°C]	121	111	106	101	98	95	94	92	89	90	88
	P _e [kW]	2,4	2,8	3	3,55	4	4,7	5,2	5,8	6,1	6,4	7,2
	P _m [kW]	3	4	4	5,5	5,5	5,5	7,5	7,5	7,5	7,5	12
	n [min ⁻¹]	2023	2324	2596	2925	3264	3861	4186	4688	4966	5232	5830
	n _m [min ⁻¹]	2890	2905	2905	2925	2925	2925	2930	2930	2930	2930	2915
	Elmotor	100-2	112-2	112-2	132-2	132-2	132-2	132-2	132-2	132-2	132-2	132-2
	i	112/160	112/140	118/132	125/125	125/112	132/100	200/140	200/125	200/118	200/112	200/100
	X	1/XPA	1/XPA	1/XPA	1/XPA	1/XPA	1/XPA	1/XPA	1/XPA	1/XPA	2/XPZ	1/XPA
	L _{mA} [dB]	72/82	73/83	73/84	74/85	74/86	75/87	76/88	78/89	79/90	80/93	84/106
	80	Q [m ³ ·h ⁻¹]		83	100	119	139	174	193	221	237	253
T ₃ [°C]			128	120	114	110	107	105	101	100	99	98
P _e [kW]			3,2	3,6	4	4,5	5,4	5,9	6,5	6,9	7,3	8,2
P _m [kW]			4	5,5	5,5	5,5	7,5	7,5	12	12	12	12
n [min ⁻¹]			2324	2614	2925	3264	3868	4186	4664	4941	5205	5830
n _m [min ⁻¹]			2905	2925	2925	2925	2930	2930	2915	2915	2915	2915
Elmotor			112-2	132-2	132-2	132-2	132-2	132-2	132-2	132-2	132-2	132-2
i			112/140	118/132	125/125	125/112	132/100	200/140	200/125	200/118	200/112	200/100
X			1/XPA	1/XPA	1/XPA	1/XPA	1/XPA	1/XPA	1/XPA	1/XPA	1/XPA	2/XPZ
L _{mA} [dB]			74/85	75/86	75/88	76/89	77/90	79/91	79/98	79/99	80/100	84/107
90		Q [m ³ ·h ⁻¹]			98	116	136	172	191	219	235	250
	T ₃ [°C]			138	131	125	119	117	115	114	113	111
	P _e [kW]			4,1	4,5	5,1	6,1	6,6	7,4	7,8	8,3	9,4
	P _m [kW]			5,5	5,5	7,5	7,5	12	12	12	12	12
	n [min ⁻¹]			2615	2925	3270	3868	4164	4664	4941	5205	5830
	n _m [min ⁻¹]			2925	2925	2930	2930	2915	2915	2915	2915	2915
	Elmotor			132-2	132-2	132-2	132-2	132-2	132-2	132-2	132-2	132-2
	i			118/132	125/125	125/112	132/100	200/140	200/125	200/118	200/112	200/100
	X			1/XPA	1/XPA	1/XPA	2/XPZ	1/XPZ	2/XPZ	2/XPZ	2/XPZ	2/XPZ
	L _{mA} [dB]			77/88	74/95	75/96	76/97	79/98	79/99	79/100	81/101	84/108
	100	Q [m ³ ·h ⁻¹]					135	169	217	233	249	
T ₃ [°C]						139	132	129	126	124		
P _e [kW]						5,6	6,7	7,2	8,2	8,7	9,2	
P _m [kW]						7,5	12	12	12	12		
n [min ⁻¹]						3270	3848	4164	4664	4941	5205	
n _m [min ⁻¹]						2930	2915	2915	2915	2915	2915	
Elmotor						132-2	132-2	132-2	132-2	132-2	132-2	
i						125/112	132/100	200/140	200/125	200/118	200/112	
X						1/XPA	2/XPZ	1/XPZ	2/XPZ	2/XPZ	2/XPZ	
L _{mA} [dB]						76/97	77/98	79/99	80/100	81/101	82/102	

Tolerancie parametrov sú podľa normy ISO 1217

BAH 20/30

Δp [kPa]		BAH 20/30										
30	Q [m ³ ·h ⁻¹]	131	160	175	200	215	230	245	262	287	308	330
	T ₃ [°C]	53	51	51	50	50	52	51	52	52	52	49
	P _e [kW]	1,6	2	2	2,2	2,6	2,6	2,8	3	3,3	3,5	3,5
	P _m [kW]	2,2	2,2	3	3	3	4	4	4	4	5,5	5,5
	n [min ⁻¹]	2312	2688	2890	3225	3429	3631	3837	4067	4402	4680	4958
	n _m [min ⁻¹]	2880	2880	2890	2890	2890	2905	2905	2905	2905	2925	2925
	Elmotor	90-2	90-2	100-2	100-2	100-2	112-2	112-2	112-2	112-2	132-2	132-2
	i	106/132	140/150	125/125	125/112	140/118	140/112	140/106	140/100	200/132	200/125	200/118
	X	1/XPZ	1/XPZ	1/XPA	1/XPA	1/XPA	1/XPA	1/XPA	1/XPA	1/XPA	1/XPA	1/XPA
	L _{mA} [dB]	70/81	70/82	71/83	72/83	73/84	74/85	74/86	76/88	77/90	77/91	80/95
40	Q [m ³ ·h ⁻¹]	126	155	171	196	212	227	245	266	285	303	325
	T ₃ [°C]	65	63	62	61	61	62	62	62	62	62	59
	P _e [kW]	2,1	2	2,6	2,9	3,1	3,4	3,7	4	4,3	4,6	4,6
	P _m [kW]	3	3	4	4	4	5,5	5,5	5,5	5,5	5,5	5,5
	n [min ⁻¹]	2312	2697	2905	3242	3447	3656	3900	4179	4432	4680	4958
	n _m [min ⁻¹]	2890	2890	2905	2905	2905	2925	2925	2925	2925	2925	2925
	Elmotor	100-2	100-2	112-2	112-2	112-2	132-2	132-2	132-2	132-2	132-2	132-2
	i	112/140	140/150	125/125	125/112	140/118	125/100	200/150	200/140	200/132	200/125	200/118
	X	1/XPZ	1/XPA	1/XPA	1/XPA	1/XPA	1/XPA	1/XPA	1/XPA	1/XPA	1/XPA	1/XPA
	L _{mA} [dB]	71/81	71/82	71/83	72/84	73/85	73/86	75/87	76/88	77/89	78/91	81/96
50	Q [m ³ ·h ⁻¹]	121	151	166	193	209	222	241	262	281	299	321
	T ₃ [°C]	79	75	74	72	72	73	72	72	72	72	69
	P _e [kW]	2,6	3	3,25	3,7	3,9	4,2	4,5	4,88	5,2	5,6	5,7
	P _m [kW]	4	4	4	5,5	5,5	5,5	5,5	7,5	7,5	7,5	7,5
	n [min ⁻¹]	2324	2711	2905	3264	3470	3656	3900	4179	4432	4680	4958
	n _m [min ⁻¹]	2905	2905	2905	2925	2925	2925	2925	2925	2930	2930	2925
	Elmotor	112-2	112-2	112-2	132-2	132-2	132-2	132-2	132-2	132-2	132-2	132-2
	i	112/140	140/150	125/125	125/112	140/118	125/100	200/150	200/140	200/132	200/125	200/118
	X	1/XPA	1/XPA	1/XPA	1/XPA	1/XPA	1/XPA	1/XPA	1/XPA	1/XPA	1/XPA	1/XPA
	L _{mA} [dB]	72/82	72/83	72/84	73/85	73/86	74/87	75/88	78/90	79/91	80/93	82/97
60	Q [m ³ ·h ⁻¹]	118	140	164	190	205	219	238	259	278	297	316
	T ₃ [°C]	93	89	86	84	83	84	83	83	82	80	79
	P _e [kW]	3,1	4	3,9	4,4	4,7	5	5,4	5,8	6,2	6,4	6,7
	P _m [kW]	4	5,5	5,5	5,5	5,5	7,5	7,5	7,5	7,5	7,5	12
	n [min ⁻¹]	2324	2614	2925	3264	3470	3663	3907	4186	4439	4688	4941
	n _m [min ⁻¹]	2905	2925	2925	2925	2925	2930	2930	2930	2930	2930	2915
	Elmotor	112-2	132-2	132-2	132-2	132-2	132-2	132-2	132-2	132-2	132-2	132-2
	i	112/140	118/132	125/125	125/112	140/118	125/100	200/150	200/140	200/132	200/125	200/118
	X	1/XPA	1/XPA	1/XPA	1/XPA	1/XPA	1/XPA	1/XPA	1/XPA	1/XPA	1/XPA	1/XPA
	L _{mA} [dB]	72/82	72/83	73/84	73/85	74/86	75/87	76/88	78/90	79/91	80/93	82/100
70	Q [m ³ ·h ⁻¹]	116	137	160	187	202	216	235	254	273	292	313
	T ₃ [°C]	108	103	99	96	95	95	94	91	90	90	89
	P _e [kW]	3,7	4	4,6	5,1	5,4	5,8	6,2	6,5	7	7,4	7,8
	P _m [kW]	5,5	5,5	5,5	7,5	7,5	7,5	7,5	12	12	12	12
	n [min ⁻¹]	2349	2614	2925	3270	3476	3663	3907	4164	4417	4664	4941
	n _m [min ⁻¹]	2925	2925	2925	2930	2930	2930	2930	2915	2915	2915	2915
	Elmotor	132-2	132-2	132-2	132-2	132-2	132-2	132-2	132-2	132-2	132-2	132-2
	i	106/132	118/132	125/125	125/112	140/118	125/100	200/150	200/140	200/132	200/125	200/118
	X	1/XPA	1/XPA	1/XPA	1/XPA	1/XPA	1/XPA	1/XPA	1/XPA	1/XPA	1/XPA	1/XPA
	L _{mA} [dB]	73/84	73/85	74/86	74/87	75/89	76/90	78/92	78/98	79/98	79/99	82/101
80	Q [m ³ ·h ⁻¹]	110	131	158	184	200	212	231	252	271	289	310
	T ₃ [°C]	123	117	112	108	107	105	103	102	101	100	99
	P _e [kW]	4,1	5	5,2	5,85	6,2	6,5	7	7,5	7,9	8,4	8,9
	P _m [kW]	5,5	5,5	7,5	7,5	7,5	12	12	12	12	12	12
	n [min ⁻¹]	2301	2574	2930	3278	3476	3644	3887	4164	4417	4664	4941
	n _m [min ⁻¹]	2925	2925	2930	2930	2930	2915	2915	2915	2915	2915	2915
	Elmotor	132-2	132-2	132-2	132-2	132-2	132-2	132-2	132-2	132-2	132-2	132-2
	i	118/150	132/150	132/132	132/118	140/118	200/160	200/150	200/140	200/132	200/125	200/118
	X	1/XPA	1/XPA	1/XPA	1/XPA	1/XPA	1/XPA	1/XPA	1/XPA	1/XPA	1/XPA	1/XPA
	L _{mA} [dB]	73/84	73/85	74/86	74/87	75/89	76/97	78/98	78/98	79/99	79/99	82/102
90	Q [m ³ ·h ⁻¹]		131	155	180	195	214	228	249	268		
	T ₃ [°C]		133	127	123	121	119	118	116	115		
	P _e [kW]		5,2	5,9	6,6	7,0	7,5	7,9	8,5	9,1		
	P _m [kW]		7,5	7,5	12	12	12	12	12	12		
	n [min ⁻¹]		2619	2930	3253	3458	3706	3887	4164	4417		
	n _m [min ⁻¹]		2930	2930	2915	2915	2915	2915	2915	2915		
	Elmotor		132-2	132-2	132-2	132-2	132-2	132-2	132-2	132-2		
	i		118/132	125/125	125/112	140/118	150/118	200/150	200/140	200/132		
	X		1/XPA	1/XPA	2/XPZ	2/XPZ	2/XPZ	2/XPZ	2/XPZ	2/XPZ		
	L _{mA} [dB]		74/95	74/95	75/96	76/97	77/98	78/99	79/100	80/102		
100	Q [m ³ ·h ⁻¹]				178	193	226	247				
	T ₃ [°C]				136	134	131	129				
	P _e [kW]				7,3	7,7	8,3	8,8				
	P _m [kW]				12	12	12	12				
	n [min ⁻¹]				3261	3458	3706	3887				
	n _m [min ⁻¹]				2915	2915	2915	2915				
	Elmotor				132-2	132-2	132-2	132-2				
	i				132/118	140/118	150/118	200/150	200/140			
	X				2/XPZ	2/XPZ	2/XPZ	2/XPZ				
	L _{mA} [dB]				76/97	77/98	78/99	79/100				

Tolerance parametrow sú podľa normy ISO 1217

BAH 30/60

Δp [kPa]	BAH 30/60											
30	Q [m ³ ·h ⁻¹]	222	260	297	330	353	376	401	425	452	483	511
	T ₃ [°C]	50	50	49	49	49	49	49	49	49	49	48
	P _e [kW]	2,5	2,8	3,2	3,5	3,7	3,9	4,2	4,4	4,7	5	5,3
	P _m [kW]	3	4	4	5,5	5,5	5,5	5,5	5,5	5,5	5,5	7,5
	n [min ⁻¹]	2550	2905	3247	3552	3767	3978	4214	4440	4691	4981	5238
	n _m [min ⁻¹]	2890	2905	2905	2925	2925	2925	2925	2925	2925	2925	2930
	Elmotor	100-2	112-2	112-2	132-2	132-2	132-2	132-2	132-2	132-2	132-2	132-2
	i	150/170	170/170	190/170	170/140	170/132	170/125	170/118	170/112	170/106	170/100	236/132
	X	1/XPA	1/XPA	1/XPA	1/XPA	1/XPA	1/XPA	1/XPA	1/XPA	1/XPA	1/XPA	1/XPA
	L _{mA} [dB]	70/81	70/82	71/83	72/83	73/84	74/85	74/86	76/88	77/90	77/91	80/95
40	Q [m ³ ·h ⁻¹]	217	256	293	323	347	370	395	420	447	474	506
	T ₃ [°C]	62	60	60	60	59	59	59	59	58	58	58
	P _e [kW]	3,3	3,8	4,2	4,6	4,9	5,2	5,5	5,8	6,2	6,6	7
	P _m [kW]	4	5,5	5,5	5,5	7,5	7,5	7,5	7,5	7,5	11	11
	n [min ⁻¹]	2563	2925	3269	3552	3773	3985	4221	4447	4699	4956	5256
	n _m [min ⁻¹]	2905	2925	2925	2925	2930	2930	2930	2930	2930	2940	2940
	Elmotor	112-2	132-2	132-2	132-2	132-2	132-2	132-2	132-2	132-2	160-2	160-2
	i	150/170	170/170	190/170	170/140	170/132	170/125	170/118	170/112	170/106	236/140	236/132
	X	1/XPA	1/XPA	1/XPA	1/XPA	1/XPA	1/XPA	1/XPA	1/XPA	1/XPA	1/XPA	1/XPA
	L _{mA} [dB]	71/81	71/82	71/83	72/84	73/85	73/86	75/87	76/88	77/89	78/91	81/96
50	Q [m ³ ·h ⁻¹]	213	250	288	318	342	363	388	413	442	469	501
	T ₃ [°C]	73	72	70	70	70	69	69	69	68	68	67
	P _e [kW]	4,1	4,7	5,3	5,7	6,1	6,4	6,8	7,2	7,7	8,1	8,7
	P _m [kW]	5,5	5,5	7,5	7,5	7,5	7,5	11	11	11	11	11
	n [min ⁻¹]	2581	2925	3275	3558	3773	3973	4200	4438	4704	4956	5256
	n _m [min ⁻¹]	2925	2925	2930	2930	2930	2930	2940	2940	2940	2940	2940
	Elmotor	132-2	132-2	132-2	132-2	132-2	132-2	160-2	160-2	160-2	160-2	160-2
	i	150/170	170/170	190/170	170/140	170/132	160/118	160/112	160/106	160/100	236/140	236/132
	X	1/XPA	1/XPA	1/XPA	1/XPA	1/XPA	1/XPA	1/XPA	1/XPA	2/XPA	1/XPA	1/XPA
	L _{mA} [dB]	72/82	72/83	72/84	73/85	73/86	74/87	75/88	78/90	79/91	80/93	82/97
60	Q [m ³ ·h ⁻¹]	208	246	283	314	336	360	383	409	437	464	497
	T ₃ [°C]	86	83	81	81	80	80	79	79	78	78	77
	P _e [kW]	4,9	5,6	6,3	6,9	7,3	7,7	8,1	8,6	9,2	9,7	10,3
	P _m [kW]	7,5	7,5	7,5	11	11	11	11	11	11	15	15
	n [min ⁻¹]	2585	2930	3275	3564	3763	3986	4200	4438	4704	4956	5256
	n _m [min ⁻¹]	2930	2930	2930	2940	2940	2940	2940	2940	2940	2940	2940
	Elmotor	132-2	132-2	132-2	160-2	160-2	160-2	160-2	160-2	160-2	160-2	160-2
	i	150/170	170/170	190/170	160/132	160/125	160/118	160/112	160/106	160/100	236/140	236/132
	X	1/XPA	1/XPA	1/XPA	1/XPA	1/XPA	1/XPA	2/XPA	2/XPA	2/XPA	1/XPA	1/XPA
	L _{mA} [dB]	73/84	73/85	74/86	75/87	76/88	76/89	77/90	78/92	79/94	80/95	82/99
70	Q [m ³ ·h ⁻¹]	204	243	285	310	332	356	379	405	433	460	493
	T ₃ [°C]	98	95	93	92	91	90	90	89	88	88	87
	P _e [kW]	5,7	6,5	7,4	8	8,4	9	9,5	10	10,6	11,3	12
	P _m [kW]	7,5	11	11	11	11	11	11	15	15	15	15
	n [min ⁻¹]	2585	2940	3332	3564	3763	3986	4200	4438	4704	4956	5256
	n _m [min ⁻¹]	2930	2940	2940	2940	2940	2940	2940	2940	2940	2940	2940
	Elmotor	132-2	160-2	160-2	160-2	160-2	160-2	160-2	160-2	160-2	160-2	160-2
	i	150/170	170/170	170/150	160/132	160/125	160/118	160/112	160/106	160/100	236/140	236/132
	X	1/XPA	1/XPA	1/XPA	1/XPA	1/XPA	2/XPA	2/XPA	2/XPA	2/XPA	1/XPA	2/XPA
	L _{mA} [dB]	73/85	74/86	75/86	76/87	77/89	77/90	78/91	79/93	80/94	81/97	82/100
80	Q [m ³ ·h ⁻¹]	201	239	282	307	328	352	375	401	430	457	489
	T ₃ [°C]	111	107	104	103	102	101	100	99	99	98	97
	P _e [kW]	6,6	7,5	8,5	9,1	9,6	10,2	10,8	11,4	12,1	12,8	13,6
	P _m [kW]	11	11	11	11	15	15	15	15	15	15	18,5
	n [min ⁻¹]	2594	2940	3332	3564	3763	3986	4200	4438	4704	4956	5256
	n _m [min ⁻¹]	2940	2940	2940	2940	2940	2940	2940	2940	2940	2940	2940
	Elmotor	160-2	160-2	160-2	160-2	160-2	160-2	160-2	160-2	160-2	160-2	160-2
	i	150/170	170/170	170/150	160/132	160/125	160/118	160/112	160/106	160/100	236/140	236/132
	X	1/XPA	1/XPA	1/XPA	2/XPA	2/XPA	2/XPA	2/XPA	2/XPA	2/XPA	2/XPA	2/XPA
	L _{mA} [dB]	74/86	75/87	75/88	77/89	77/90	78/91	79/92	80/94	81/95	82/99	83/102
90	Q [m ³ ·h ⁻¹]	197	235	278	303	324	348	372	397	426	453	486
	T ₃ [°C]	126	121	117	115	114	112	111	110	110	109	108
	P _e [kW]	7,4	8,4	9,5	10,2	10,8	11,5	12,1	12,8	13,6	14,4	15,3
	P _m [kW]	11	11	15	15	15	15	15	15	18,5	18,5	18,5
	n [min ⁻¹]	2594	2940	3332	3564	3763	3986	4200	4438	4704	4956	5256
	n _m [min ⁻¹]	2940	2940	2940	2940	2940	2940	2940	2940	2940	2940	2940
	Elmotor	160-2	160-2	160-2	160-2	160-2	160-2	160-2	160-2	160-2	160-2	160-2
	i	150/170	170/170	170/150	160/132	160/125	160/118	160/112	160/106	160/100	236/140	236/132
	X	1/XPA	1/XPA	2/XPA	2/XPA	2/XPA	2/XPA	2/XPA	2/XPA	2/XPA	2/XPA	2/XPA
	L _{mA} [dB]	75/87	76/88	77/89	77/89	78/90	78/91	79/92	80/95	81/96	83/100	84/104
100	Q [m ³ ·h ⁻¹]	232	275	300	322	346	369	395	423	450	483	511
	T ₃ [°C]	133	129	127	125	124	122	121	120	120	119	119
	P _e [kW]	9,3	10,6	11,3	12,0	12,7	13,4	14,2	15,1	15,1	16,0	16,0
	P _m [kW]	11	15	15	15	15	18,5	18,5	18,5	18,5	18,5	18,5
	n [min ⁻¹]	2940	3332	3564	3763	3986	4200	4438	4704	4956	4956	5256
	n _m [min ⁻¹]	2940	2940	2940	2940	2940	2940	2940	2940	2940	2940	2940
	Elmotor	160-2	160-2	160-2	160-2	160-2	160-2	160-2	160-2	160-2	160-2	160-2
	i	170/170	170/150	160/132	160/125	160/118	160/112	160/106	160/100	236/140	236/140	236/132
	X	1/XPA	2/XPA	2/XPA	2/XPA	2/XPA	2/XPA	2/XPA	3/XPA	2/XPA	2/XPA	2/XPA
	L _{mA} [dB]	77/89	77/90	78/91	78/91	79/92	80/93	81/96	82/97	84/102		

Tolerancie parametrov sú podľa normy ISO 1217

BAH 40/60

Δp [kPa]	BAH 40/60											
30	Q [m ³ ·h ⁻¹]	264	312	362	413	455	487	517	552	585	622	664
	T ₃ [°C]	51	50	50	49	50	49	49	49	49	50	49
	P _e [kW]	3	3,4	4	4,4	4,9	5,2	5,5	5,9	6,2	6,7	7,2
	P _m [kW]	4	5,5	5,5	5,5	7,5	7,5	7,5	7,5	7,5	11	11
	n [min ⁻¹]	2256	2581	2925	3269	3558	3773	3985	4221	4447	4704	4989
	n _m [min ⁻¹]	2905	2925	2925	2925	2930	2930	2930	2930	2930	2940	2940
	Elmotor	112-2	132-2	132-2	132-2	132-2	132-2	132-2	132-2	132-2	132-2	160-2
	i	132/170	150/170	170/170	190/170	170/140	170/132	170/125	170/118	170/112	160/100	224/132
	X	1/XPA	1/XPA	1/XPA	1/XPA	1/XPA	1/XPA	1/XPA	1/XPA	1/XPA	1/XPA	1/XPA
	L _{mA} [dB]	70/82	71/83	72/84	72/85	73/86	74/87	74/88	76/89	77/91	78/92	80/95
40	Q [m ³ ·h ⁻¹]	258	304	355	406	447	480	510	541	576	615	656
	T ₃ [°C]	63	61	60	60	60	59	59	59	59	59	59
	P _e [kW]	4	4,5	5,2	5,8	6,4	6,8	7,2	7,6	8,1	8,7	9,3
	P _m [kW]	5,5	5,5	7,5	7,5	7,5	11	11	11	11	11	11
	n [min ⁻¹]	2271	2581	2930	3275	3558	3786	3986	4200	4438	4704	4989
	n _m [min ⁻¹]	2925	2925	2930	2930	2930	2940	2940	2940	2940	2940	2940
	Elmotor	132-2	132-2	132-2	132-2	132-2	160-2	160-2	160-2	160-2	160-2	160-2
	i	132/170	150/170	170/170	190/170	170/140	170/132	160/118	160/112	160/106	160/100	224/132
	X	1/XPA	1/XPA	1/XPA	1/XPA	1/XPA	1/XPA	1/XPA	2/XPA	2/XPA	2/XPA	1/XPA
	L _{mA} [dB]	71/82	72/84	72/85	73/86	73/87	74/88	75/89	77/90	78/91	79/93	81/97
50	Q [m ³ ·h ⁻¹]	252	297	348	407	442	474	503	534	569	608	650
	T ₃ [°C]	75	73	71	70	70	70	69	69	69	69	68
	P _e [kW]	5	5,6	6,4	7,4	7,9	8,4	8,9	9,4	10	10,7	11,4
	P _m [kW]	7,5	7,5	7,5	11	11	11	11	11	15	15	15
	n [min ⁻¹]	2275	2585	2930	3332	3570	3786	3986	4200	4438	4704	4989
	n _m [min ⁻¹]	2930	2930	2930	2940	2940	2940	2940	2940	2940	2940	2940
	Elmotor	132-2	132-2	132-2	160-2	160-2	160-2	160-2	160-2	160-2	160-2	160-2
	i	132/170	150/170	170/170	170/150	170/140	170/132	160/118	160/112	160/106	160/100	224/132
	X	1/XPA	1/XPA	1/XPA	1/XPA	1/XPA	1/XPA	2/XPA	2/XPA	2/XPA	2/XPA	2/XPA
	L _{mA} [dB]	72/83	72/84	73/85	73/86	74/88	74/89	75/90	78/91	80/92	81/94	82/98
60	Q [m ³ ·h ⁻¹]	245	293	344	401	436	468	497	529	564	603	644
	T ₃ [°C]	87	84	82	81	80	80	79	79	79	78	78
	P _e [kW]	6	6,8	7,7	8,8	9,4	10	10,6	11,2	11,9	12,7	13,5
	P _m [kW]	7,5	11	11	11	11	15	15	15	15	15	18,5
	n [min ⁻¹]	2275	2594	2940	3332	3570	3786	3986	4200	4438	4704	4989
	n _m [min ⁻¹]	2930	2940	2940	2940	2940	2940	2940	2940	2940	2940	2940
	Elmotor	132-2	160-2	160-2	160-2	160-2	1650-2	160-2	160-2	160-2	160-2	160-2
	i	132/170	150/170	170/170	170/150	170/140	170/132	160/118	160/112	160/106	160/100	224/132
	X	1/XPA	1/XPA	1/XPA	1/XPA	2/XPA	2/XPA	2/XPA	2/XPA	2/XPA	2/XPA	2/XPA
	L _{mA} [dB]	73/85	73/86	74/87	75/88	76/89	76/90	77/91	78/93	79/95	80/96	83/100
70	Q [m ³ ·h ⁻¹]	241	287	339	396	431	463	493	524	559	598	640
	T ₃ [°C]	100	96	93	92	91	90	90	89	89	88	87
	P _e [kW]	7	7,9	9	10,2	11	11,7	12,3	13	13,8	14,7	15,7
	P _m [kW]	11	11	11	15	15	15	15	18,5	18,5	18,5	18,5
	n [min ⁻¹]	2283	2594	2940	3332	3570	3786	3986	4200	4438	4704	4989
	n _m [min ⁻¹]	2940	2940	2940	2940	2940	2940	2940	2940	2940	2940	2940
	Elmotor	160-2	160-2	160-2	160-2	160-2	160-2	160-2	160-2	160-2	160-2	160-2
	i	132/170	150/170	170/170	170/150	170/140	170/132	160/118	160/112	160/106	160/100	224/132
	X	1/XPA	1/XPA	1/XPA	2/XPA	2/XPA	2/XPA	2/XPA	2/XPA	2/XPA	3/XPA	2/XPA
	L _{mA} [dB]	73/86	74/87	75/88	76/89	77/90	78/91	79/92	80/93	81/94	82/97	83/101
80	Q [m ³ ·h ⁻¹]	237	283	334	396	427	459	488	520	555		
	T ₃ [°C]	113	108	105	103	102	101	100	100	99		
	P _e [kW]	7,9	9	10,2	11,7	12,5	13,3	14	14,8	15,7		
	P _m [kW]	11	11	15	15	15	18,5	18,5	18,5	18,5		
	n [min ⁻¹]	2283	2594	2940	3360	3570	3786	3986	4200	4438		
	n _m [min ⁻¹]	2940	2940	2940	2940	2940	2940	2940	2940	2940		
	Elmotor	160-2	160-2	160-2	160-2	160-2	160-2	160-2	160-2	160-2		
	i	132/170	150/170	170/170	160/140	170/140	170/132	160/118	160/112	160/106		
	X	2/XPA	2/XPA	2/XPA	2/XPA	2/XPA	2/XPA	2/XPA	2/XPA	3/XPA		
	L _{mA} [dB]	74/87	75/88	76/89	77/90	78/91	79/92	80/93	81/95	82/96		
90	Q [m ³ ·h ⁻¹]	232	279	330	392	423	454	484				
	T ₃ [°C]	128	123	118	115	113	112	111				
	P _e [kW]	8,9	10,1	11,5	13,2	14,0	14,9	15,7				
	P _m [kW]	11	15	15	18,5	18,5	18,5	18,5				
	n [min ⁻¹]	2283	2594	2940	3360	3570	3786	3986				
	n _m [min ⁻¹]	2940	2940	2940	2940	2940	2940	2940				
	Elmotor	160-2	160-2	160-2	160-2	160-2	160-2	160-2				
	i	132/170	150/170	170/170	160/140	170/140	170/132	160/118				
	X	2/XPA	2/XPA	2/XPA	2/XPA	2/XPA	2/XPA	2/XPA				
	L _{mA} [dB]	75/88	76/89	77/90	79/91	79/92	80/93	81/94				
100	Q [m ³ ·h ⁻¹]											
	T ₃ [°C]											
	P _e [kW]											
	P _m [kW]											
	n [min ⁻¹]											
	n _m [min ⁻¹]											
	Elmotor											
	i											
	X											
	L _{mA} [dB]											

Tolerancie parametrov sú podľa normy ISO 1217

- Q [m³·h⁻¹] – Výkonosť dýchadlového sústrojenstva na sani
 Δp [kPa] – Tlaková diferencia
 T_3 [°C] – Teplota na výtláčnej prírubě
 P_e [kW] – Príkion dýchadla
 P_m [kW] – Výkon motora
 n [min⁻¹] – Otáčky dýchadla
 n_m [min⁻¹] – Otáčky motora
 El motor – Osová výška a počet pólov elektromotora
 i [mm] – Priemer remenice motora / Priemer remenice dýchadla
 X – Počet a druh klinových remeňov
 L_{mA} [dB] – Hladina akustického tlaku sústrojenstva s krytom a bez krytu
 $p_0 = 101$ kPa, $t_1 = 20$ °C, $N_v = 0$ m / nad morom, suchý vzduch
 $\Delta p = p_3 - p_0$

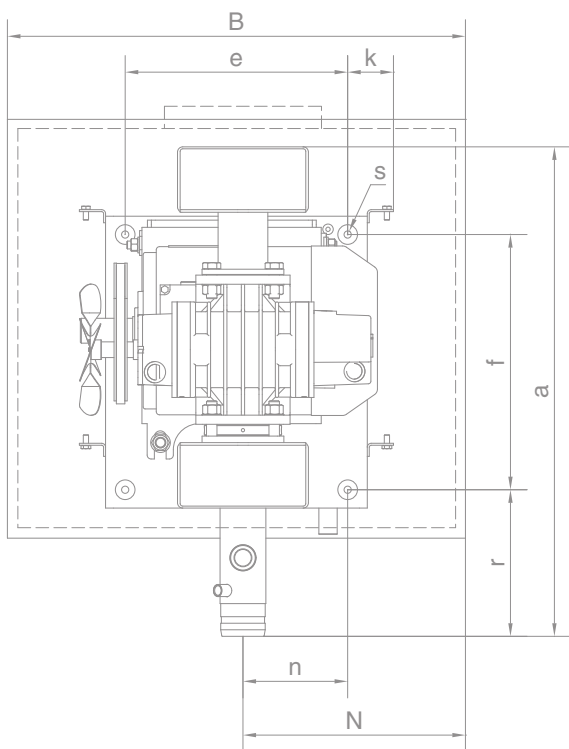
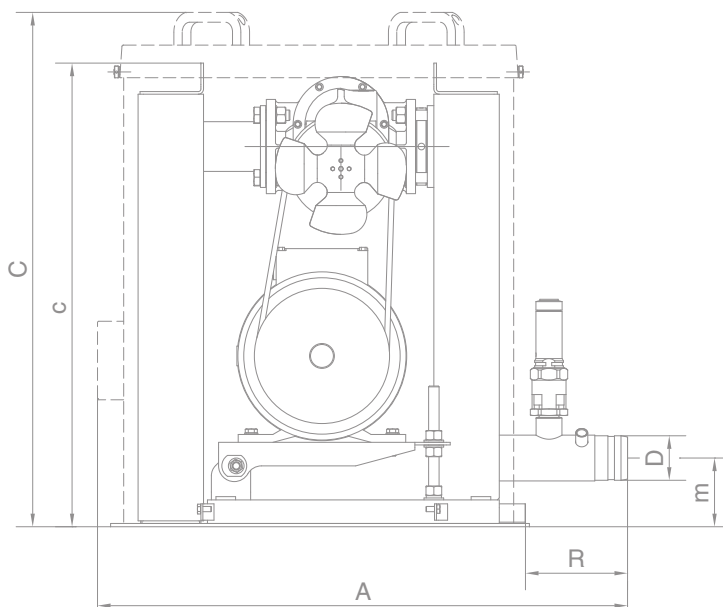
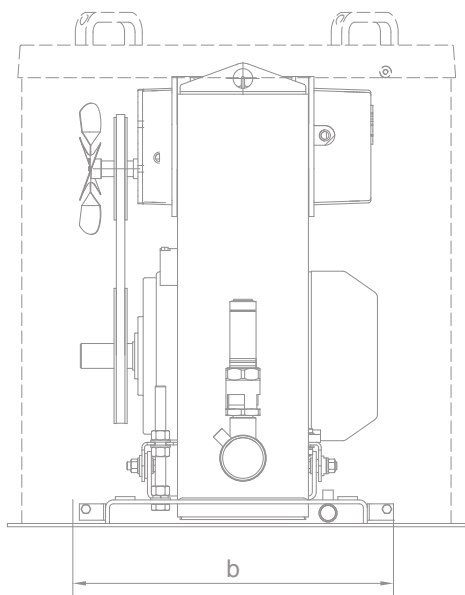

	BAH 6/10	BAH 10/30	BAH 20/30	BAH 30/60	BAH 40/60
A	682	810	810	1030	1030
B	590	700	700	879	879
C	659	786	786	940	940
D	59	68	68	88	88
N	286	340	340	411	411
R	132	156	156	172	172
a	602	748	748	955	955
b	380	490	490	620	620
c	577	715	715	867	867
e	250	340	340	444	444
f	320	390	390	530	530
k	60	70	70	78	78
m	104	105	105	124	124
n	116	160	160	193	193
r	197	224	224	240	240
s	11	11	11	13	13
DN	DN 50/PN 10	DN 65/PN 10	DN 65/PN 10	DN 80/PN 10	DN 80/PN 10
kg^{*)}	47	95	99	176	185
kg^{**)}	25	33	33	76	76

^{*)} Hmotnosť bez elektromotora

^{**)} Protihlukový kryt

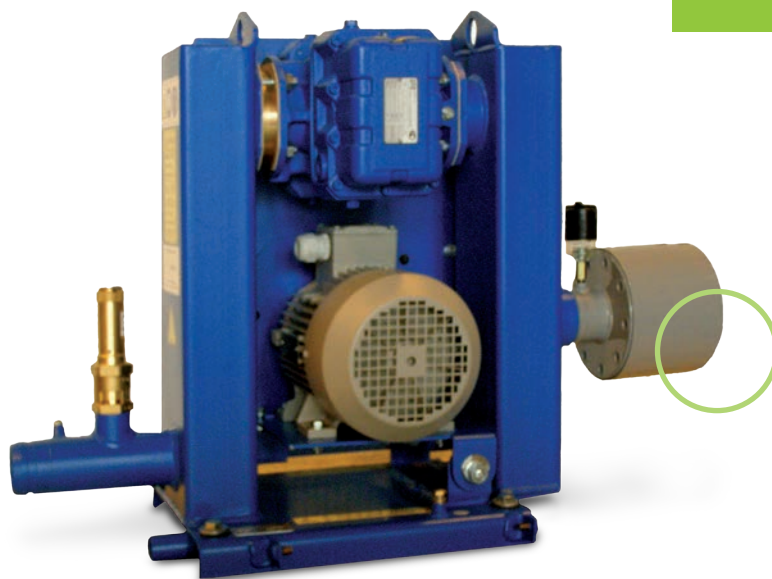

Filter Solberg pre jemnú filtráciu

Protihlukový kryt



Manometer na výtlaku

Kompenzátor s prírubou na výstupe

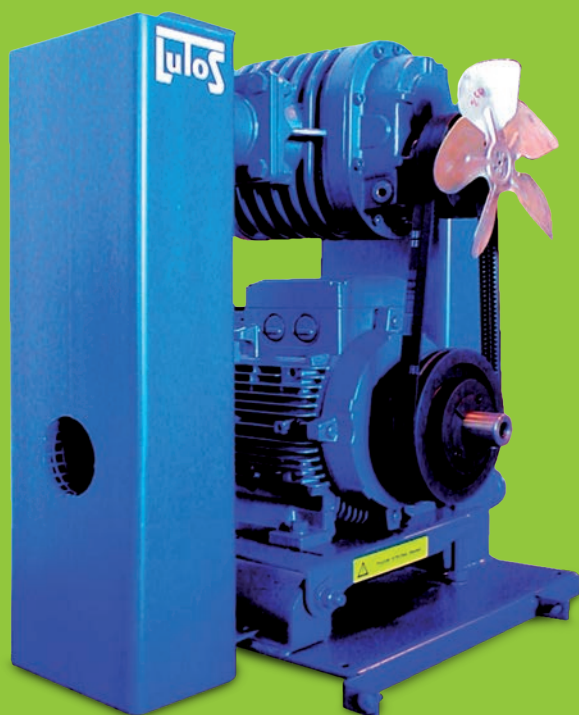

INECO®

IN-ECO, spol. s r.o.
Radlinského 13
034 01 Ružomberok
Slovak Republic
T +421 44 4304662
E info@in-eco.sk
www.in-eco.sk

1.6.2022